

NEIGHBORHOOD CRIME WATCH TRAINING MANUAL

PRESENTED BY

**BOB HOLDER, SHERIFF
COMAL COUNTY SHERIFF'S OFFICE
3005 W. SAN ANTONIO ST.
NEW BRAUNFELS, TX 78130
(830) 620-3400
(830) 885-4883**

**TEXAS CRIME PREVENTION ASSOCIATION, INC.
P.O. BOX 180515 AUSTIN, TX 78757-1505**



WHAT IS NEIGHBORHOOD WATCH?

Crime or the fear of crime provides the impetus for the citizens to become better informed on how to protect themselves and their property.

Getting back to the old adage of being our "**brothers keepers**", neighbors watching out for other neighbors. Neighbors are asked to be the eyes and ears in helping the police in apprehending criminals. Crime Watch is not designed to substitute for police protection, rather it is an extension or supplement in assisting the police in making neighborhoods safer for all citizens.

Neighborhood Watch operates under two principles. Neighbors getting to know and watch out for each other and watching out for each others property as though it was their own. Neighborhood Watch helps to create an identity within the neighborhood which in turn fosters a sense of pride and belonging for the participants.

The participants make their neighborhood a safer place to live by adopting a more observant and active attitude and as a result become more aware of strange cars, persons, or circumstances. This will not take a lot of time and soon will develop into a daily habit of becoming more aware of what is going on in the neighborhood.

YOUR ROLE AS A CRIME WATCHER

Your first and most important duty is to be an active and responsible watcher in your neighborhood.

The prevention of crime in your community is a shared responsibility between law enforcement and private citizens.

No number of officers or squad cars can completely combat the problem alone.

It is absolutely essential that a concerned citizen join hands with law enforcement in an active joint campaign to reduce residential crime.

This is where Crime Watch enters the picture. Your role as a crime watcher is to be an extra set of eyes and ears in your neighborhood.

Very simply, Crime Watch involves:

Neighbors getting to know each other and working together in a program of mutual assistance.

Neighbors being trained to be more alert in reporting suspicious activity.

Implementation of other crime deterrents such as participation in the Operation Identification property marking program, other basic home security measures and improved personal habits.

The citizens of your community can play a major role in the reduction of residential crime through active Neighborhood Crime Watch.

Unlocked doors, open windows and poorly lighted areas provide some of the opportunity that residential criminals look for.

The elimination of that opportunity, coupled with the active reporting of suspicious activity, provides the foundation for crime watch in your community. This, in turn, makes your neighborhood a nice place to live.

CRIME WATCH PARTICIPANT GUIDELINES

Participation in Crime Watch is not something that takes a lot of time. It does require each person to adopt a more observant and active attitude on a daily basis.

As a result, neighbors will get to know each other better and will become more aware of strange cars, persons or circumstances which might require calling the police.

What participants do to make their homes more secure and how alert they become is entirely up to them. The more prepared individuals are, the more effective will be the weapon against crime.

- * Get to know the neighbors. Know their names and be able to identify them and their vehicles by sight.
- * Maintain a map of the immediate neighborhood with names and address.
- * Make the home as unattractive to a burglar as possible.
- * Mark all property for identification using the "operation identification" program.
- * Be observant and watch over neighbors homes, especially when they are not at home or out of town.
- * Write down license numbers and descriptions of suspicious-looking vehicles and persons in the neighborhood and report them to the police immediately.
- * Report information that may be helpful in solving a crime to the police.
- * Educate children in crime prevention and teach respect and friendship for law enforcement and police officials.

FACT VS. MYTH

- MYTH:** Neighborhood Watch areas do not work.
- FACT:** Working programs reduce crime as much as 80%. Criminals have said that the Neighborhood Watch programs scare them into other neighborhoods.
- MYTH:** Neighborhood Watch areas are nothing more than a click.
- FACT:** Neighborhood Watch groups are for everyone in the block or area, and everyone gets to take part.
- MYTH:** To be part of a Neighborhood Watch group, I would have to dropout of something else.
- FACT:** Neighborhood Watch takes very little of your time. All you need to do is watch what is going on, report suspicious activity that you see in your area, and attend any neighborhood meetings.
- MYTH:** The Police Department runs your Neighborhood Watch program.
- FACT:** Your Neighborhood Watch program belongs to your area. The police will help to start your program and after that, it belongs to you. The police will assist, but you will be the voice in your program.

ADDITIONAL FACTS ABOUT NEIGHBORHOOD CRIME WATCH

Burglaries, auto thefts, rape, child abductions, and arson are the most prevalent crimes.

Household burglary is one of the easiest crime to commit and prevent...but one of the hardest to solve.

More than half of police time is spent on investigating burglaries.

Statistics show that in more than half of household burglaries, forced entry is not involved.

A majority of household burglaries occur during daylight hours.

Household burglary has a high potential for deaths or injury, where a burglar is surprised by the property owner.

HELP CATCH A CRIMINAL

No criminal wants to be **CAUGHT**. But if you **SEE or HEAR** someone breaking the law, try to **REMEMBER** what they look like and quickly **REPORT** them to the police.

The most valuable aid you can give a police officer about a crime is information on the identification of suspects. This and the facts you observe about the crime itself are the two main points on which an officer bases their investigation. These two items can, in many cases, be far more important than the findings made through scientific investigation at the scene such as finger prints, foot casts, etc. Many times such evidence is non-existent. Be sure to make a written note of as many of the following as possible. When reporting a crime or suspicious activity do not hang up the telephone until you are sure the dispatcher has all the information.

THE DESCRIPTION SHOULD INCLUDE:

SEX	RACE	AGE	HEIGHT	WEIGHT	WEAPON TYPE
HAIR					HAT (color, type)
GLASSES TYPE					TIE
TATTOOS					COAT
COMPLEXION					SHIRT
SCARS/MARKS					TROUSERS

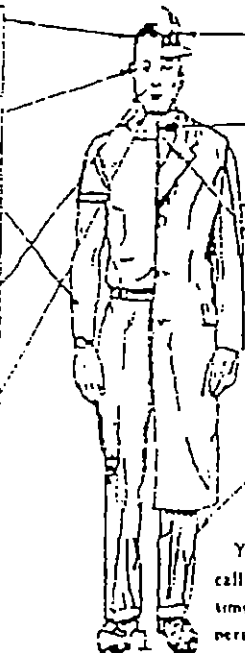

You are requested to please call the Police Department any time you see a suspicious car or person.

DESCRIBE THE VEHICLE

License Number _____

State of issue—and color of license plate _____

What color _____

What make _____

Body style _____ (2 dr., 4 dr., convertible, etc.)

Identifying scratches or dents _____

What year _____

If the vehicle leaves before the police arrive, which direction was the vehicle last seen traveling _____

REPORTING AND PURPOSE OF REPORTING

The purpose for reporting suspicious activity to the police is to stop the criminal activity, increase police presence in your neighborhood and give a true prospective of crime. Making a report will enhance the possibility of getting your property returned.

Keep police emergency numbers close by when reporting suspicious activity or an emergency. Anything that seems slightly "out of place" or does not look right could be criminal activity. **CALL THE POLICE IMMEDIATELY** about all suspicious activity. Do not worry about "bothering" the police or being embarrassed if your suspicions prove to be unfounded. Think ahead about what could happen if you don't act. Give the police or the telephone clerk:

The reason for the call.

The location of the activity.

The description of the suspect and any vehicle involved.

If the crime is in progress, give the circumstances and possible crime being committed.

WHEN IN DOUBT, CALL IT IN

Under no circumstances attempt to apprehend a person committing a crime or investigate suspicious activity. The police want your information - not your action.

The police department would rather investigate than be called when it is too late. Your call could save a life, prevent an injury or stop a criminal act. **BE ALERT**

Not every stranger who comes into your neighborhood is a criminal by any means. There are many door-to-door salesmen, repairmen, and servicemen moving around our neighborhoods all the time. But criminals do take advantage of this by pretending to be legitimate workmen.

SUSPICIOUS ACTIVITY CONCERNING VEHICLES

<u>CIRCUMSTANCE</u>	<u>POSSIBLE CRIME</u>
Slow moving vehicle, without lights, or if the course followed appears aimless. This is suspicious in any location including residential streets, schools, and playground.	Possible burglar, drug pusher, or sex offender.
Parked or occupied vehicle containing one or more persons, especially significant if observed at an unusual hour.	Possible lookouts for a or robbery.
Vehicles being loaded with valuables if parked by a business or unoccupied residence.	Possible burglary or theft in progress.
Abandoned vehicle parked on your block.	Possible stolen car.
Vehicle containing weapons.	Owner may engage in criminal activity.
Vehicle where someone is being forced into it, especially females or juveniles.	Possible kidnapping, assault, or attempted rape.
Vehicles where a business transaction is being conducted around schools or parks.	Possibly selling stolen items or drugs.
Locked vehicle that someone is attempting to forcibly enter, especially in a parking lot.	Possible theft of a car or its contents.
Persons detaching mechanical parts or accessories from a vehicle.	Possible theft or vandalism.
Objects thrown from a vehicle.	Possible disposal of contraband.

SUSPICIOUS ACTIVITY CONCERNING PERSONS

<u>CIRCUMSTANCE</u>	<u>POSSIBLE CRIME</u>
Going door to door in a residential area, especially if one or more persons goes to the rear of the residence.	Possible burglary suspects or trespassers.
Waiting or loitering in front of a house or business, if business is closed or house unoccupied.	Possible burglary suspects.
Forcing entrance, or entering your neighbors house, when it is unoccupied.	Possible burglary, theft or trespassing.
Person running, especially if something of value is being carried.	Possible suspect fleeing the scene of a crime.
Person carrying property that is not wrapped, at an unusual hour.	Possible suspect fleeing the scene of a burglary or robbery.
Much human traffic to and from a certain residence if it occurs on a daily or regular basis.	Possible drug, vice or a fence operation.
Person screaming.	Possible rape or assault.
Person loitering around cars or going car to car peering into them, especially in parking lots or on streets.	Possible car thief.
Persons loitering around schools, parks, or secluded areas.	Possible sex offenders.
Persons offering items for sale at very low price.	Possibly trying to sell stolen property.
Strangers loitering or driving through an area several times.	Possible burglary suspects.
"Delivery Man" with a wrong address or one who asks if someone else lives there.	Possible burglary suspect.

OTHER SUSPICIOUS ACTIVITY

<u>CIRCUMSTANCE</u>	<u>POSSIBLE CRIME</u>
Continuous repair operations at a nonbusiness location.	Possible stolen property being altered.
Open or broken doors and windows at a closed business or unoccupied residence.	Possible burglary in progress, completed burglary, or vandalism.
Unusual noises such as gunshots, screaming or dogs barking continuously.	Possible burglary, assault, rape, etc.
Sound of breaking glass.	Possible burglary or vandalism.
A person exhibiting unusual mental or physical symptoms.	Person may be injured, under the influence of drugs, or otherwise needing medical attention.
Property in homes, garage, or storage areas is suspicious if accumulations are large, or items are in good condition but not in use.	Possible stolen property.

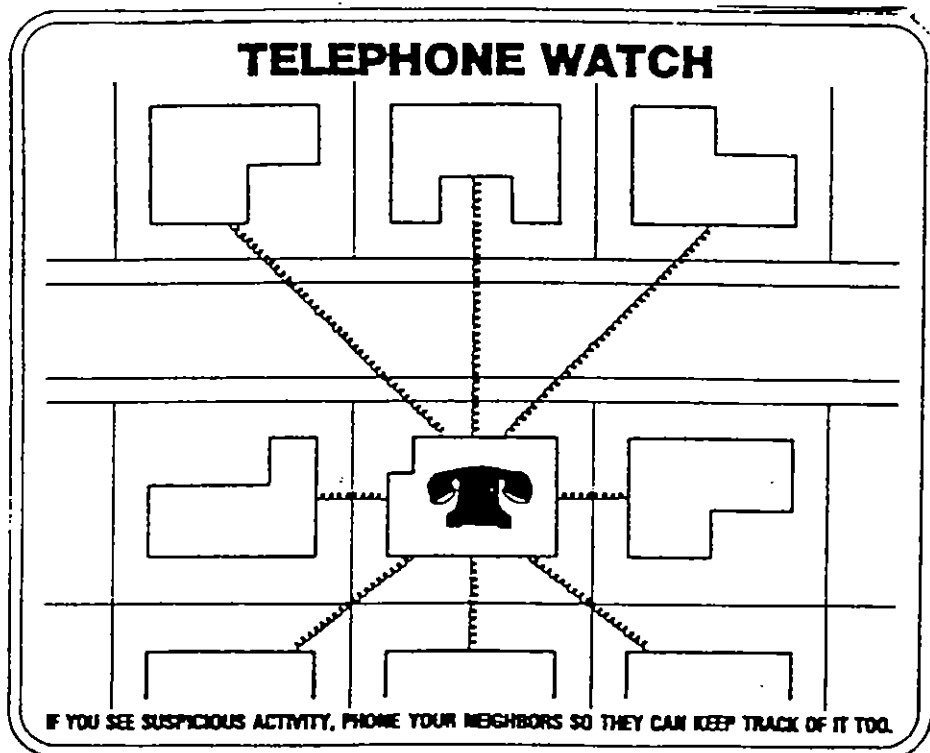

HOME SECURITY

In an **EMERGENCY**, can the Police, Fire Department or Ambulance find your home quickly and easily from the street or other entrance way?

Permanent placement of numbers should be no less than 3" in height on both the front and rear of a residence designating the official post office address. **EXCEPTION:** If there is no rear entrance the rear number is not required, but it is recommended.

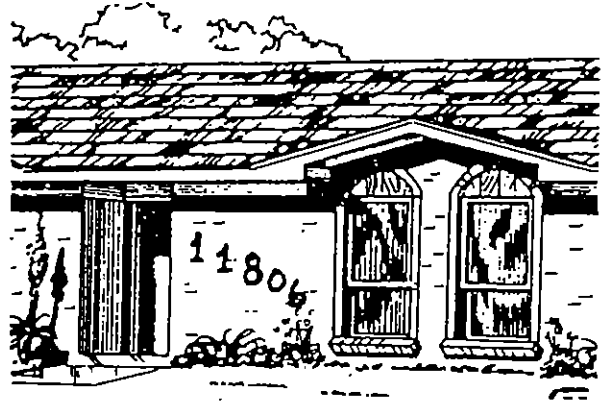

Can a prowler, burglar or vandal hide in the shadows of the night around your home?

One of the best sources of cost effective protection around your home is adequate exterior lighting. Lighting has proven to be an effective deterrent against persons with criminal intent.



Effective lighting should be: 1) placed to illuminate as many sides of the house as possible; 2) placed under the eaves of the house or shielded with a protective covering to prevent tampering and; 3) kept on during all nighttime periods.

An inexpensive timer or photoelectric cell will automatically turn light on at dusk and off at dawn.

potential criminal hide there?

What about your bushes and landscaping? Could a

The security of your home also depends on visibility. Your home should maintain its visibility so that neighbors and police patrols can watch for illegal activity. Ornamental plant growth should be kept well trimmed, especially around doors and windows where a person could hide while breaking into your home.

In planning your landscape, you might consider discouraging intruders from window areas by planting prickly or stickertype plants (i.e., roses, some hollies, pyracantha).

Do you have a privacy fence that obstructs your neighbors' view of your backyard? Are your fence crossrails on the outside presenting a stepladder-type entry into your backyard? What about your gate; is it secured?

Privacy fencing is a disadvantage to home security since it provides concealment. Other forms of fencing would eliminate this disadvantage but here are some methods to offset this problem:

1. Remove every other slat along the alley side of the fence to allow greater visibility.
2. Plant a hostile-type plant to cover the outside of the fence (i.e., climbing roses with large thorns or pyracantha).
3. Padlock your gate so that entry is made more difficult (for more information, see section on padlocks).

*If your fence has not been built, have the installer place the crossrails on the inside of the fence.

NOW THAT WE'VE WALKED AROUND THE OUTSIDE OF YOUR HOUSE, LET'S GET READY TO GO INSIDE AND LOOK FOR QUESTIONS AND ANSWERS.....

Let's go to the front door - as I walk up to the door, can you see me from the inside? Do you know who is outside before you open it?

A good idea here is to install a wide-angle viewer (peephole) in the door. This will let you know who is on the outside before the door is open. (A 190 degree view is recommended).

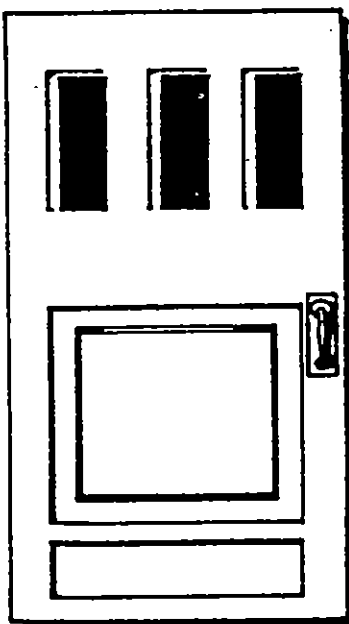
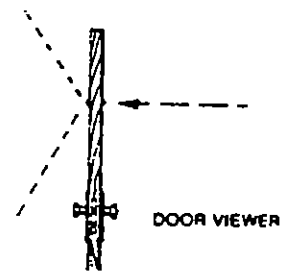

Now, how about that door? Is it solid core? Is it metal? Is it cracked or splitting? How thick is it?

Not only your front door, but all of your exterior doors and the door between your house and the garage should be of solid core construction or heavy gauge metal with a minimum thickness of 1 3/8 inches. A thinner door may give if kicked. And if your door is the panel-type, make sure joints haven't come unglued and panels are not split or rotten.

While we are looking at the door, let's have a look at the strikeplate on the door frame. Is yours of light weight metal installed with short wood screws?

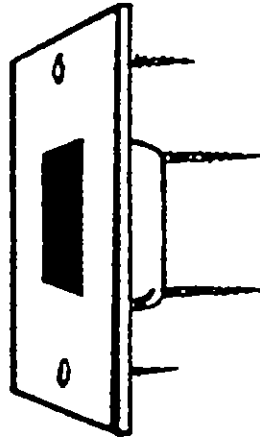

The recommendation here is that your metal strikeplate should be installed with wood screws of a minimum length of 3 inches. Better yet, install a heavier gauge security strikeplate and again use the longer screws. The screws should take you past the frame and reach all the way into the structural 2 x 4s.

Now for **LOCKS**. Do you just have the lock-in-the-knob type lock? Is your latch, spring loaded?

The lock-in-the-knob offers you privacy and convenience but not security from intruders. In fact, many lock-in-the-knob locks

can be slipped using a simple credit card or screwdriver. For safety you need a secure lock.

The recommended lock is a **DEADBOLT LOCK** with the following features: For fire safety purposes it should be *Single Cylinder *with a minimum 1" bolt throw, *Rotating Cylinder Guard, *Five pin Tumbler and *Hardened Steel Interlocking screws.



STANDARD DEADLOCK

CYLINDER DEADLOCKS

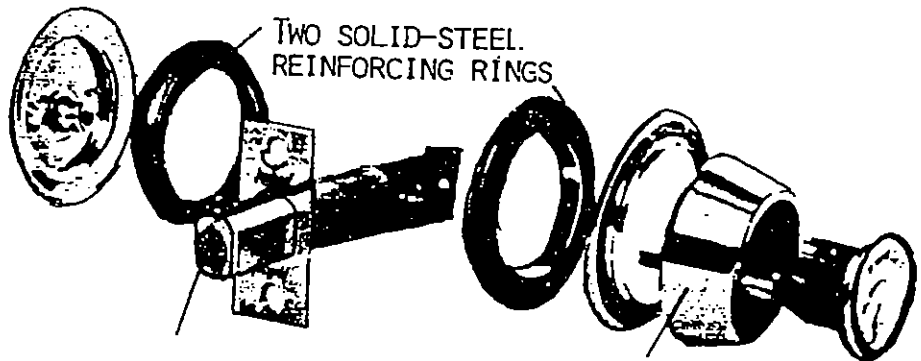

FLUSH BOLT

Another consideration in doors, is French or Double doors.

In a pair of double doors, to make them secure, one of the doors must be made inactive. This can be accomplished with the installation of flush bolts at the top and bottom of the door that are secured into metal strikeplates. A deadbolt may then be added to the active door.

Other types of doors in the home must also be adequately secured. Sliding glass doors are particularly vulnerable to attacks by burglars.

Secure sliding doors to keep them from sliding or being pried up and out of the track by: Pinning:—Drill a slightly downward sloping hole through top portion of the sliding door frame. Insert a pin as illustrated. This will help secure the door from being pried open. To keep it from being lifted out of its track you can place 2 or 3 screws in the top track that allow just enough room for the door to open and close but will not allow the door to be lifted.

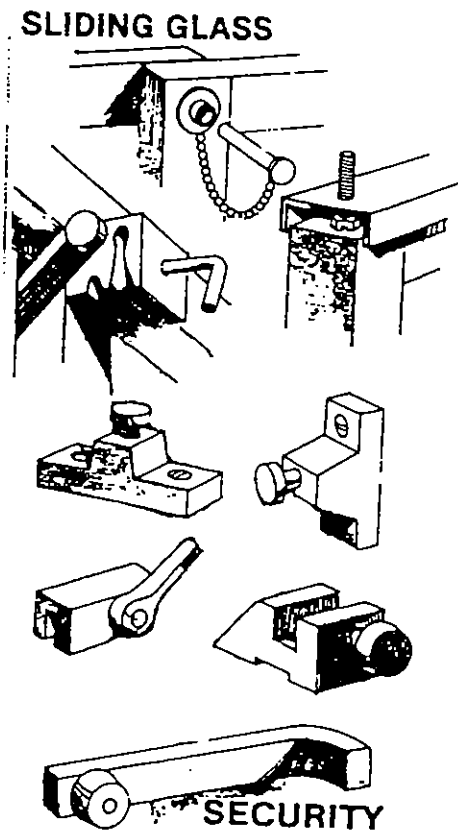
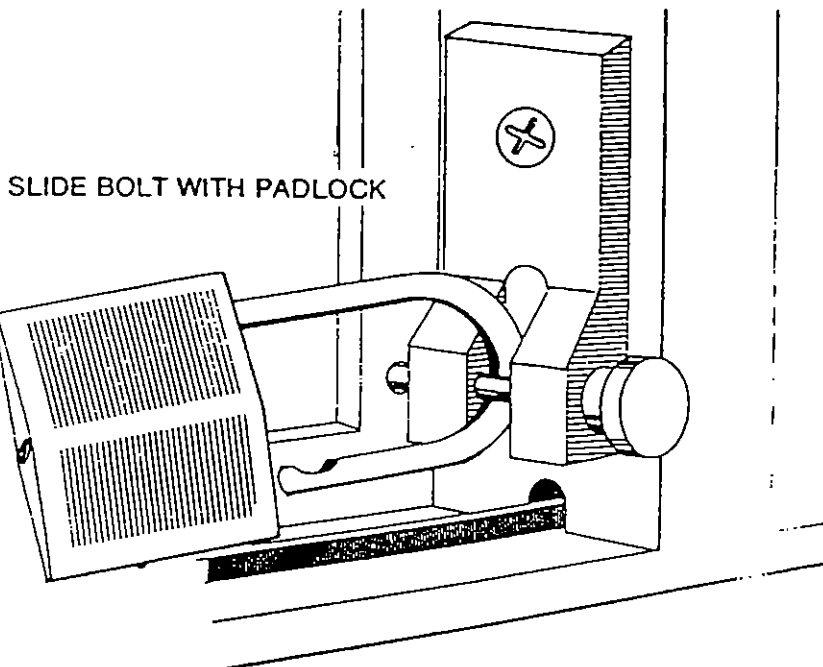
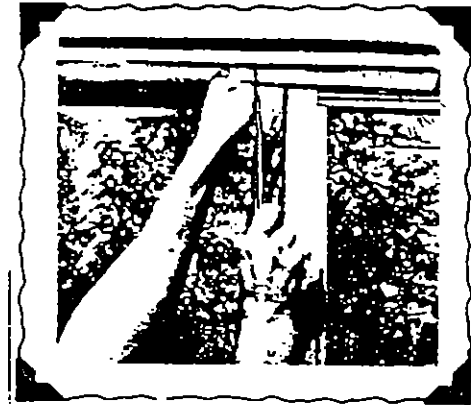
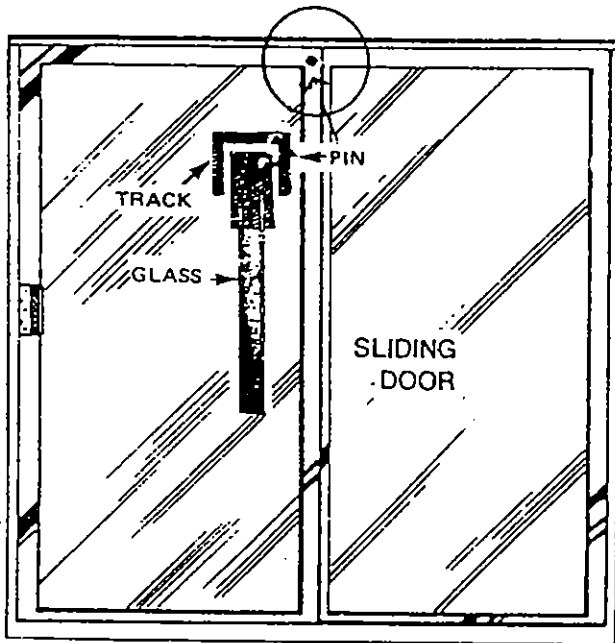

While we're checking out all of your exterior doors, let's take a look at the hinges. Are any of your hinges exposed to the outside?

If you find your hinges are exposed to the outside, we recommend that you pin the hinges or replace the hinges with those having non-removable hinge pins.

JUST A REMINDER THAT THE RECOMMENDATIONS MADE ON DOORS ARE TO INCLUDE ALL EXTERIOR DOORS AS WELL AS THE DOOR BETWEEN YOUR GARAGE AND YOUR HOME.

Windows are next, since they are often used by burglars as an entry point into homes. First, let's look at the type of windows you have: are they aluminum frame? wooden? double hung? single hung? sliding? casement or jalousied? Have you added any type of auxiliary locks to your windows?

Because of your windows' vulnerability, it is recommended that a supplementary lock be installed on all moving windows. Most windows slide vertically or horizontally and can be secured in several different ways.

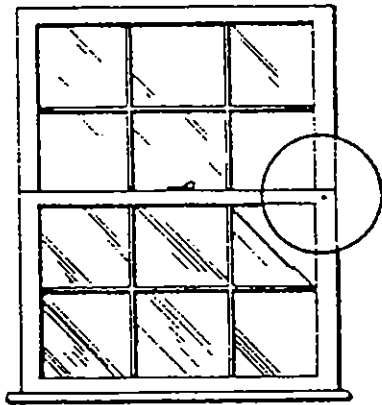

DOUBLE HUNG

Pinning a window shut reduces the chances that the window can be pried open. This is accomplished by drilling a hole at a slightly downward angle through both the movable and fixed window frame and placing a pin, nail or eyebolt in the hole.

Remember to allow for easy removal from the inside for fire escape safety.

Other methods include placing a tight-fitting dowel in the track of the window or a commercial thumb-screw lock in the track.

Storm windows can also offer extra security by requiring a burglar to go through two panes of glass instead of one. Casement windows are a little more difficult to secure, but make sure that the latch works properly and that the "operator" has no excess play. Replace worn hardware.

We discourage the use of key-operated locks on windows because of the fire hazard. Be careful that any method you use will not hinder the escape of family members in a fire emergency.

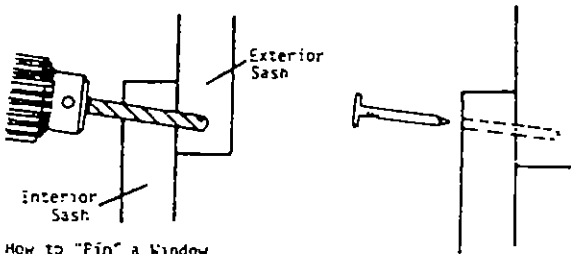

How to "Pin" a Window

1. Drill a hole through the inside sash and three-quarters of the way through the outside sash on a down-sloping angle (as shown).
2. Insert pin or nail.

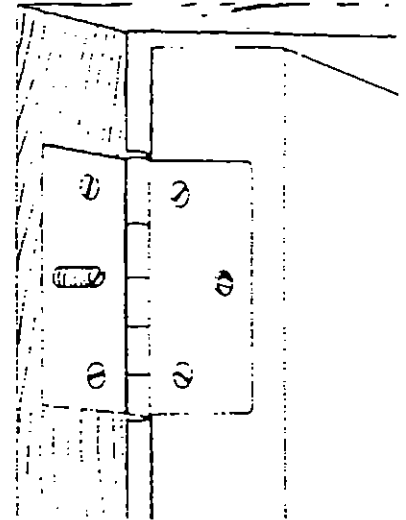

Now that we've been through most of your house, let's go into your garage and have a look around. We've already discussed the point that the door from your house into your garage should be secured with a deadbolt lock and should be of the same construction as exterior doors. Now that we're in the garage, how about the garage door itself? Is it deteriorating and easily bypassed? Does it have windows? How about a garage door opener? Does the cord release for your garage door opener hang by the door when your door is closed?

Most garage doors, due to their construction, are difficult to secure. Several recommendations can be made, however:



Keep garage doors closed and locked at all times.

Remove any knobs or rings from an automatic garage door release. With these in place, an intruder can place a coat hanger through the top of the garage door and pull the cord (or break a window and reach in), releasing the garage door from the track.

Cover the garage window to prevent persons from viewing inside. It makes it more difficult for someone to determine whether you are home or not. Mirrored film on your windows allows you to see out but doesn't allow them to see in.

While on vacation, place a padlock through the track. If your door is deteriorating or you are considering replacement, a windowless garage metal door provides the most security.

And while we're in the garage, let's look up. Do you have an attic access in the garage?

If your attic access is in the garage and another inside your residence, the garage attic access should be secured. This can be accomplished by adding a case-hardened hinging hasp and padlock. This prevents an intruder from going through the attic, if he does get into the garage.

NOTE: WE HAVE ATTACHED A SECURITY CHECKLIST AT THE END OF THIS MANUAL FOR YOU TO EVALUATE YOUR HOME SECURITY.

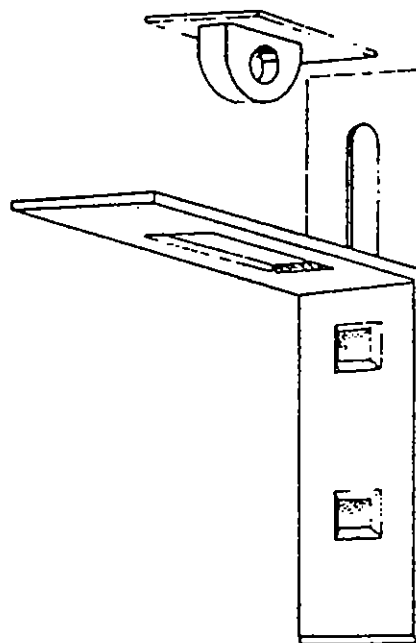

SLIDING HASP

MISCELLANEOUS SECURITY INFORMATION

ALARMS Offer additional security but should never be substituted for good locks and physical hardware. It is important to remember that alarms do not actually keep anybody out, but merely signal when someone has or is attempting to break in. The most effective alarm is one which combines a local bell or siren attached to your house and is also monitored by an alarm company. In the event the alarm company receives an alarm signal from your home, they call the police department. Before purchasing an alarm, conduct a thorough investigation of the company from which you intend to buy. Make sure that it is a reputable company that will give you good service. Check with your local police agency to see if they require an alarm permit.

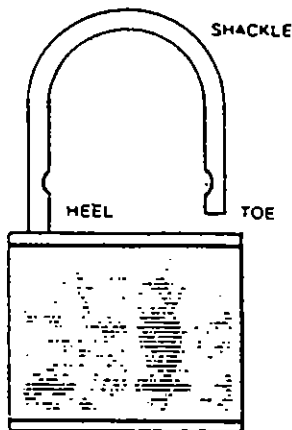

PADLOCKS

Do not economize on a padlock that will not give you the protection you need. The most common assault on a padlock is with a large bolt cutter or pry bar. The following description is the minimum standard for an exterior padlock:

1. Case hardened steel, with a 9/32" shackle
2. Locking mechanism in both the heel and toe

Record and then remove the "key code numbers" from all padlocks. This number, normally located on the bottom of the padlock, enables someone to have a key made for the padlock.

WHERE ARE YOUR KEYS?

You've defeated the purpose of locks if you don't know where the keys are. If there's a chance that a former owner or tenant might still have a key—have a locksmith rekey your locks. This might be a good time to evaluate how good your locks are and consider upgrading to a better lock.

Also, where is your garage door opener? Is it in your locked/unlocked vehicle in your drive? Is it in your car that you left for service? Is it in your car everyday, while you are at work, sitting on the console in the parking lot? **TREAT YOUR GARAGE DOOR OPENER WITH AS MUCH SECURITY AS YOU DO YOUR HOUSE KEY - IT'S AN ELECTRONIC KEY TO YOUR HOME.**

NOTE: WHEN GOING ON VACATION, USE THE VACATION CHECK OFF LIST TO ASSIST YOU IN THE PREPARING YOUR RESIDENCE TO BE UNOCCUPIED.

VACATION CHECK-OFF LIST

1. Lock all doors, including the garage door. _____
2. Lock all windows, including basement and garage windows. _____
3. Cancel all deliveries such as newspapers, food services, etc. _____
4. Have mail and newspapers picked up by a neighbor if possible. _____
5. Have someone pick up handbills and throwaways. _____
6. Never leave a note on the door that may indicate your absence. _____
7. Arrange to have the lawn cut or the snow shoveled. _____
8. Adjust blinds and draperies to make the house or apartment appear to be occupied. _____
9. Place a light or two on automatic timers. _____
10. Remove ladders from sight and secure them in locked places. _____
11. Don't hide keys under doormats or flowerpots or in or in similar places. _____
12. Secure items such as jewelry, furs, cameras, credit cards, and checkbooks. _____
13. Arrange for a house-sitter, someone to live in your house while you are away, if possible. _____
14. Arrange for a neighbor to keep an eye on your property and to report anything suspicious to police. _____
15. Let a neighbor know where you can be reached in case of an emergency. _____
16. Arrange with a neighbor to leave his or her car parked in your driveway or in front of your house or apartment. _____
17. Leave a radio on just inside your doorway. _____
18. Lower the tone on your telephone. _____
19. Ask neighbors not to tell strangers such as salespersons and repair persons of your absence. _____
20. Do not advertise your absence in the local social notices. _____
21. Notify your local law-enforcement agency of your absence. _____

BURGLARY PREVENTION CHECKLIST FOR HOMES

This checklist was designed to help you make a security survey of your own home.

The first purpose of home security inspection is to identify features in your home or daily routines of your family which might make your home an easy target for a burglar.

The security inspection should begin at your front door, include an inspection of all your doors and windows, locks, lights and landscaping. Each question on the checklist which you answer with an "x" or checkmark in the second column indicated a security weakness or hazard which requires your attention.

Yes No

DOORS

- | | | |
|--|---|---|
| 1. Are all outside doors in the house of metal or solid wood construction? | — | — |
| 2. Are all exterior doors equipped with single cylinder deadbolt locks? | — | — |
| 3. Are door frames strong enough and tight enough to prevent forcing or spreading? | — | — |
| 4. Are door hinges protected from removal from outside? | — | — |
| 5. Are all door locks adequate and in good repair? | — | — |
| 6. Are all exterior doors equipped with heavy duty strike plates with a minimum of 3 inch screws to secure it? | — | — |
| 7. Has the hole in the door jamb, surrounded by the strike plate, been drilled at least 1 inch deep? | — | — |
| 8. Can the locking mechanism be reached through a mail slot, delivery port or pet entrance at doorway? | — | — |
| 9. Is there a screen or storm door with an adequate lock? | — | — |
| 10. Are all entrances lighted with at least a 40 watt light? | — | — |
| 11. Are outside lights controlled by timers or photo-electric cells, for automatic operation? | — | — |
| 12. Can front entrance be observed from street or public area? | — | — |

- 13. Do you know everyone who has a key to your residence? — —
- 14. Have you had your locks rekeyed? — —
- 15. Does porch or landscaping offer concealment from view from street or public area? — —
- 16. If there is a sliding glass door, is the sliding panel secured from being lifted out of track? — —
- 17. Is "charley-bar" or key operated auxiliary lock used on sliding glass doors? — —

BASEMENTS

- 18. Are all entrances to living quarters from garage, porch, balcony and basement of metal or solid wood construction? — —
- 19. Does door from basement to living quarters have an adequate lock operated from living quarters side? — —
- 20. Is there a door from outside to the basement? — —
- 21. If so, is that door adequately secure for an exterior door? — —
- 22. Is outside basement entrance lighted by exterior light of at least 40 watts? — —
- 23. Is outside basement door concealed from street or neighbors? — —
- 24. Are all basement windows adequately secured against entrance? — —

WINDOWS

- 25. Do all windows have adequate locks in operating condition? — —
- 26. Do windows have screens or storm windows that lock from inside? — —
- 27. Do the windows opening to hazardous areas or offering increased risk of burglary have additional security? — —
- 28. Do windows that open to hazardous areas have security screens, grills or bars that open from the inside? — —

- 29. Are exterior areas of windows free from concealing structure or landscaping? — —
- 30. Is exterior adequately lighted at all window areas? — —
- 31. Are trees and shrubbery kept trimmed back from upper and lower floor windows? — —
- 32. Have ladders kept outside the house where they are accessible been secured? — —

GARAGE DOORS AND WINDOWS

- 33. Is automobile entrance door to garage equipped with adequate locking device? — —
- 34. Is garage door kept closed and locked at all times? — —
- 35. Are garage windows secured adequately for ground floor windows? — —
- 36. Is outside utility entrance to garage as secure as required for any ground floor entrance? — —
- 37. Are all garage doors lighted on the outside by at least a 40 watt light? — —
- 38. Does door from garage to living quarters have locks adequate for exterior entrance? — —
- 39. Do you remove your garage door openers from unattended vehicles? — —
- 40. Do you lock your vehicles and take the keys out even when it is parked in your garage? — —

REMEMBER: ANY QUESTIONS ANSWERED WITH A NO, SHOULD BE GIVEN CONSIDERATION FOR A SECURITY OR PROCEDURE CHANGE.

OTHER SECURITY CONSIDERATIONS:

SAFE PRACTICES

Do you plan so that you do not need to "hide" a key under the door mat?

Do you keep as much cash as possible, other valuables and a home inventory in a bank?

Have you engraved all of your property with your drivers license number and included the state?

Do you have a list of the serial numbers of your watches, cameras, typewriters, T.V.'s, stereos, and all items that have serial numbers?

Do you have a description of other valuable property that does not have a number?

Do you avoid unnecessary display or publicity of your valuables?

Have you told your family what to do if they discover a burglar breaking in or already in the house?

Have you told your family to leave the house undisturbed and call the police if they discover a burglary has been committed?

This checklist was designed to help you go through your home and make a check to see that you are not inviting a burglary by having an "open house". The checklist covers the common areas of weakness in residential security.

If you would like professional advise and assistance in a thorough home security inspection contact your local crime prevention program.

*To keep your guard, take a critical look at your home security every three to four months. Don't become lax--**crime prevention is a continuous process.***

Secondary Barrier-Security Closet

If you have valuable items such a silverware or jewels, consider a secondary barrier. Install a solid core wood door with a 1 " deadbolt on a closet. Store your valuables in that area. Also, be sure to pin the hinges. If you use your master bedroom closet it can become a momentary hiding place to flee in the event of an intruder. It would be even more effective if a cordless telephone were inside the closet to allow calling 911 and alerting the police to the intruder.

Keep coin and stamp collections in a safe deposit box.

OPERATION IDENTIFICATION

This program has been tested and proven not only in Texas but throughout the United States. By taking part in Operation Identification you can greatly increase the risk that criminals must take if they steal your property.

HOW IT WORKS

Operation Identification operates in the following manner:

The Texas drivers license of the head of the household is marked in some permanent manner on all valuable property, eg. TX00649415.

DO NOT MARK PROPERTY WITH A SOCIAL SECURITY NUMBER. Marking should be in a prominent place, which can be easily observed without dismantling the object.

We suggest that an electric engraving pencil be used. You may borrow an engraver from most public libraries, or law enforcement agencies. If not the crime watch group may wish to purchase an engraver to share throughout the crime watch. These are available at most craft shops.

Valuables that can not be marked should be photographed and kept in a safe place. After you have marked your property you may request Operation I.D. window decals.

WARNING

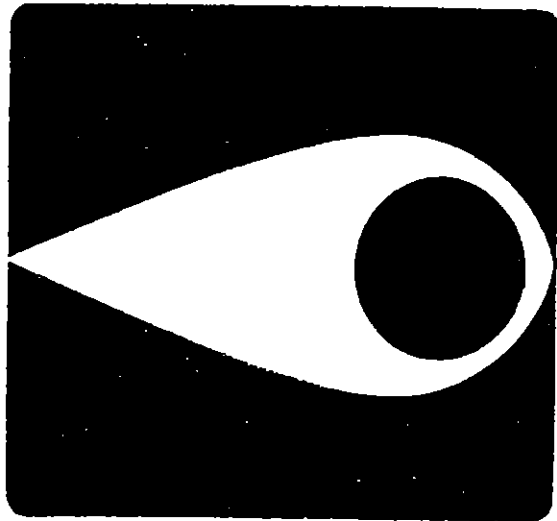

All items of value on these premises have been marked for ready identification by Law Enforcement Agencies.

OPERATION I.D.
A Project Of Your Local
Law Enforcement Agency

REQUIREMENTS FOR REDUCTION IN HOMEOWNERS INSURANCE PREMIUMS

Exterior doors are solid core that are 1 3/8 inches thick and are secured by dead-bolt locks. Dead-bolt locks must lock with a minimum bolt throw of one inch that penetrates a metal strike plate. If the door secured by the dead-bolt lock has breakable glass within 40 inches of the lock, the lock must be key-operated from both sides unless prohibited by life safety codes.

Metal doors are secured by dead-bolt locks as described below.

Double doors meet the specification for exterior doors as listed above, have the inactive door secured by headers and threshold bolts that penetrate metal strike plates, and in case of glass located within 40 inches of header and threshold bolts, have the bolts flush-mounted in the edge of the door.

Sliding glass doors are secured by secondary locking devices to prevent lifting and prying.

Dutch doors have concealed flush-bolt locking devices to interlock upper and lower halves and are secure by a dead-bolt lock as described above.

Garage doors are equipped with key-operated locking devices.

Windows are secured by auxiliary locking devices. An auxiliary locking device required by this section must include screws, wooden dowels, pinning devices, and key-operated locks. In areas in which life safety codes permit, metal bars or grating, if mounted to prevent easy removal, may be substituted for auxiliary locking devices. Jalousie or louvered windows do not meet the specifications of this section unless they have metal grating mounted as provided for above.

*Once you have complied with the requirements listed above call the crime prevention division to schedule an appointment.

ALARMS:

Property is equipped with an electronic burglar that meets the following requirements:

All exterior structure openings are contacted; the system includes an interior and exterior siren; all equipment is U.L. approved and is monitored by a U.L. approved central station; and sales, service, installation, and monitoring of the system are done in compliance with the Private Investigations and Private Security Agencies Act (Article 4413 (29bb), Vernons Texas Civil Statutes).

NOTE: Please allow two weeks advance notice while scheduling.

CRIME PREVENTION SERVICES FOR RESIDENTS/HOMEOWNERS

HOME SECURITY SURVEYS

By appointment. A police officer trained in Crime Prevention will come to your residence to complete a security survey and make recommendations on how to improve your current security.

TEXAS INSURANCE INSPECTION

A police officer certified as a Crime Prevention Inspector will perform an insurance inspection to ascertain whether or not your home qualifies for a homeowners insurance reduction.

OTHER SERVICES

Services offered to citizens vary by each department. Please contact your Crime Prevention Unit to become better informed on all of the different services available to you in your area.

